

2 Tonne - The all-round machine

Small size and great strength are a powerful combination. The 2 Tonne Electric remote demolition machine packs many times the hitting power of a jackhammer in a unit small enough to fit through most doorways. What's more, the lightweight precision digital remote control allows you to operate the machine at a safe distance from the work area.

MOTOR: 18.5Kw
HEIGHT: 1392mm
WIDTH: 800mm

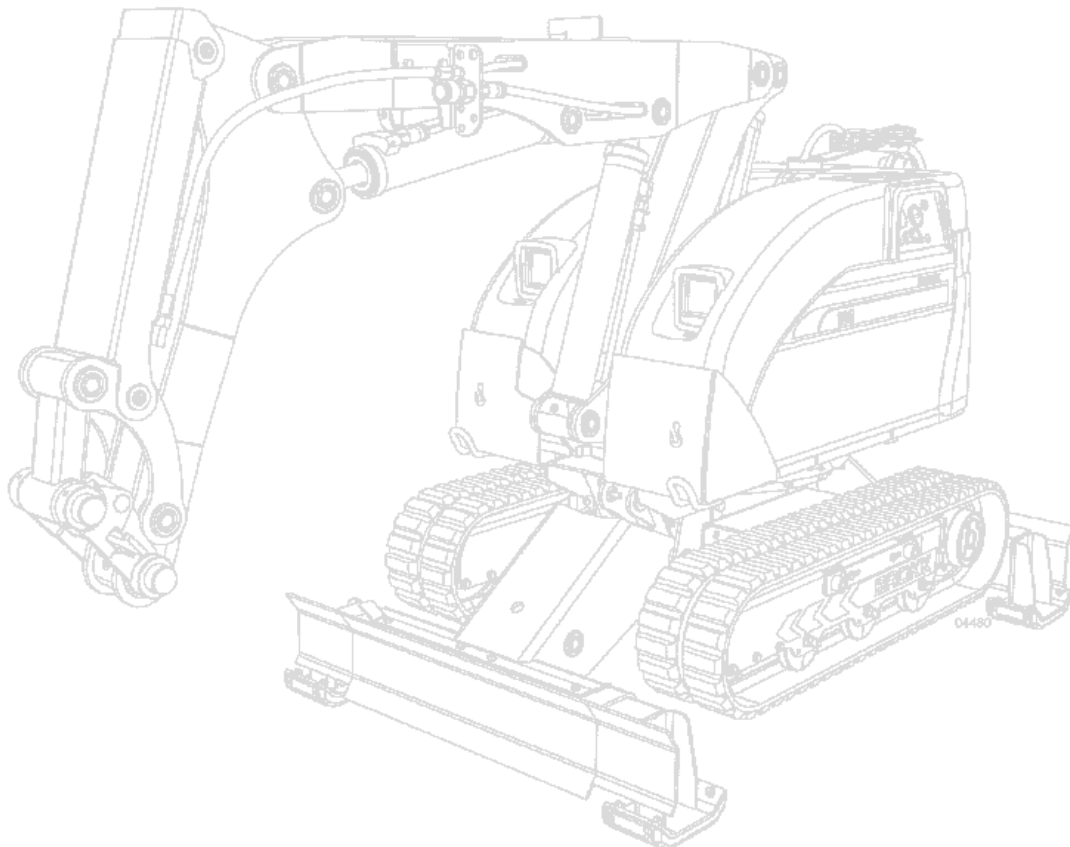

Technical Data

Hydraulic breaker in illustrations	SBC 410
Load and stability diagram can be ordered	
Performance	
Slewing speed	10 sec/360°
Transport speed, max.	2,9 km/h; 0,81 m/s; 1,8 mph
Incline angle, max.	30°
Hydraulic system	
Hydraulic system capacity	55 l; 15,5 US gal
Pump type	Variable load-sensing piston pump
System pressure to cylinders and motors, max.	18 MPa; 2610 psi
System pressure, increased to attachment, max	25.0 MPa; 3626 psi
System pressure, decreased to attachment, variable between	10-18 MPa; 1450-2610 psi
Pump flow max*	50Hz 62 l/min; 16,4 US gal/min 60Hz 74 l/min; 19,7 US gal/min
* Max pump flow and max system pressure cannot be delivered at the same time as the engine will overload.	
Electric motor	
Type	ABB M3AA 160 LB 4
Output	See type plate
RPM	See type plate
Voltage/frequency	See type plate
Current	See type plate
Starting device	Smooth start
Control system	
Control type	Portable control box
Signal code	Digital
Transfer	Cable/Radio
Weight	
Basic machine with dozer blade excl tools	1840 kg; 4060 lbs
Basic machine with flap down outriggers excl tools	1930 kg; 4250 lbs
Optional telescopic arm	230 kg; 510 lbs
Noise level	
Sound power level Lwa, measured according to directive 2000/14/EC 85,8 dB(A)	

